

MECHANICAL BACKFLOW PREVENTION INSTALLATION

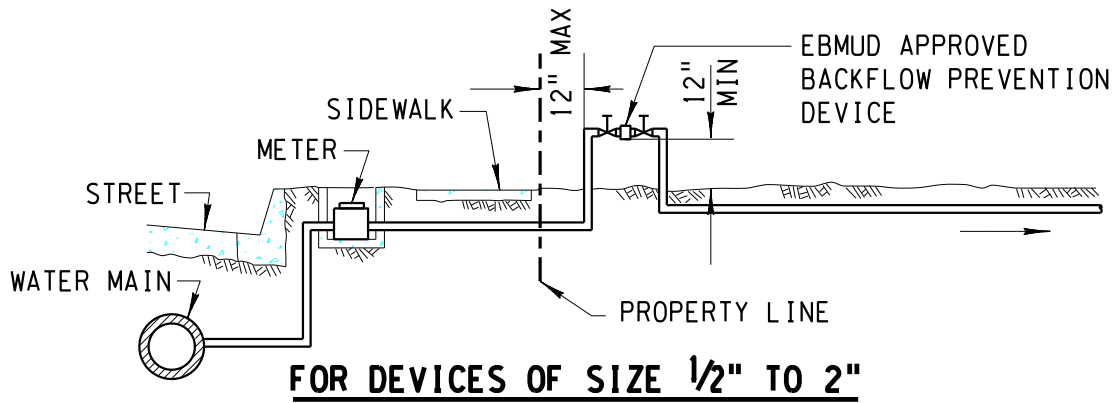

FOR DEVICES OF SIZE 1/2" TO 2"

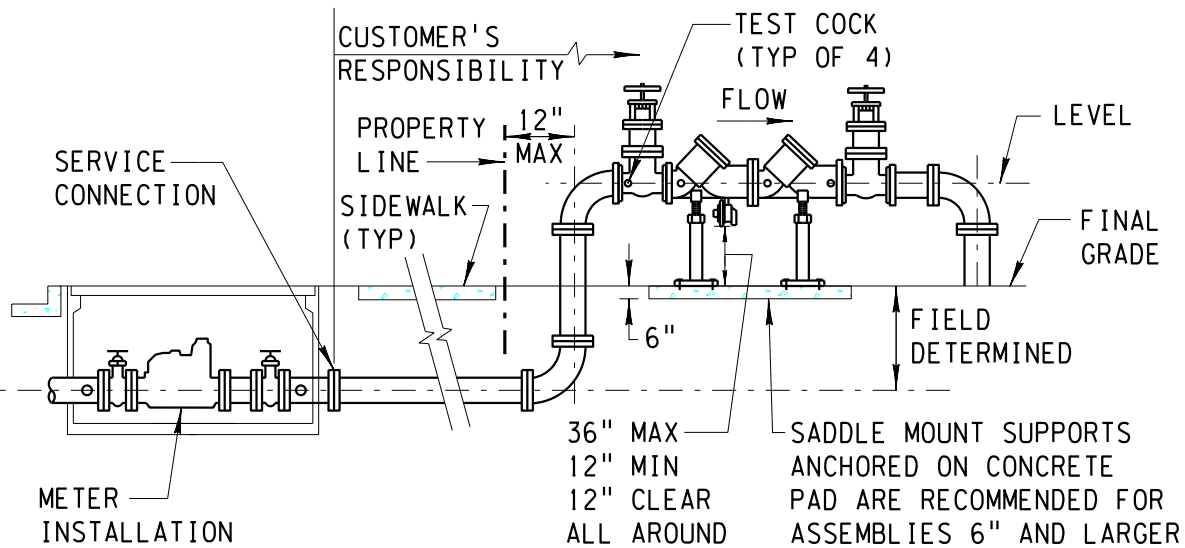

FOR DEVICES OF SIZE 2 1/2" AND LARGER

NOTES:

1. USE ONLY BACKFLOW ASSEMBLIES THAT ARE APPROVED BY THE EBMUD BACKFLOW SECTION.
2. THE SUPPLY SHALL SURFACE AT A DISTANCE OF NO MORE THAT 12 INCHES FROM THE PROPERTY LINE.
3. REDUCED PRESSURE PRINCIPLE (RPS) ASSEMBLIES SHALL BE INSTALLED IN AREAS WITH ADEQUATE DRAINAGE.
4. NO CONNECTIONS WILL BE ALLOWED BETWEEN THE SERVICE CONNECTION (WATER METER) AND THE BACKFLOW ASSEMBLY.
5. HEIGHT OF THE BACKFLOW ASSEMBLY SHALL BE AT LEAST 12" ABOVE GRADE TO THE BOTTOM OF THE ASSEMBLY (A MAXIMUM OF 36" ABOVE GRADE) AND A 12" PERIMETER AROUND THE ASSEMBLY.
6. ALL SERVICES WITH A BACKFLOW ASSEMBLY REQUIRE A PRESSURE RELIEF VALVE (PRV) ON WATER HEATERS.
7. PROTECTION FROM FREEZE DAMAGE OR THEFT MIGHT BE NECESSARY IN EXPOSED AREAS.
8. VAULT INSTALLATION OF DOUBLE-CHECK VALVES (DC) MAY BE USED IN CERTAIN LOCATIONS AND ONLY WITH PRIOR APPROVAL OF THE DISTRICT. SEE STANDARD DRAWINGS 1928-A AND 1930-A.
9. INSTALL DIRECTLY AFTER THE SERVICE CONNECTION AS SHOWN ABOVE. OBTAIN APPROVAL PRIOR TO INSTALLATION IF THERE IS ANY DEVIATION.

DESIGN	DESIGNED BY EBMUD	REVIEW	DESIGN CHECKED BY <i>D. J. Piles</i>	CORROSION CHECK BY	EAST BAY MUNICIPAL UTILITY DISTRICT OAKLAND, CALIFORNIA
	DRAWN BY BK		STANDARD DRAWING MECHANICAL BACKFLOW PREVENTION INSTALLATION METHODS FOR WATER SERVICES		
				<i>Mark Lewis</i> SENIOR MECHANICAL ENGINEER R.P.E. NO. M29694	STRUCTURE OR ZONE DESIGNATION
				<i>D. J. Piles</i>	SCALE NONE
				RECOMMENDED MGR PIPELINE INFRASTRUCTURE R.P.E. NO. C48598	DATE 23 SEP 14
				APPROVED, DIRECTOR OF ENGINEERING <i>James D. ...</i>	1931-A-1
				R.P.E. NO. C44782	

FILE: H:\general\std-dwg\1931-A-1.dgn
 PLOT: DATE: 11-06-14 11:41 AM BY: ...